

S-110 Drone

A super robust and stable drone for high precision and long endurance missions

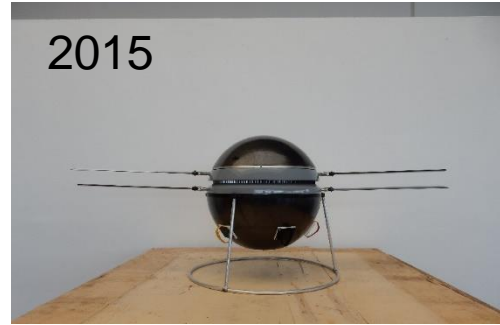

Project main milestones



Specifications of S-110 Drone

- Engine : Wankel 30 kW
- Available electrical power : 180 W
- Rotor diameter : 2.98 m
- MTOW : 110 kg
- Empty weight : 56 kg
- Max Payload : 50 kg
- Fuel capacity : 40 l
- Cruise speed 80 km/h
- Max Range 400 km*
- Endurance 11h at 20 kg payload

* Depending on navigation system

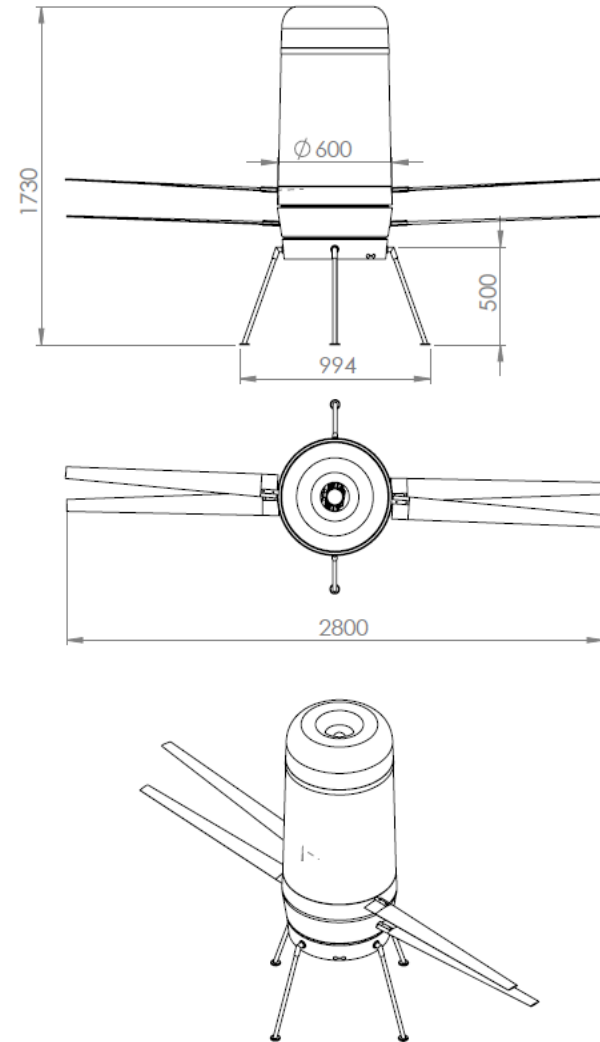

S-110 drone market:

- Surveillance: long endurance 11h mission with 20 kg payload

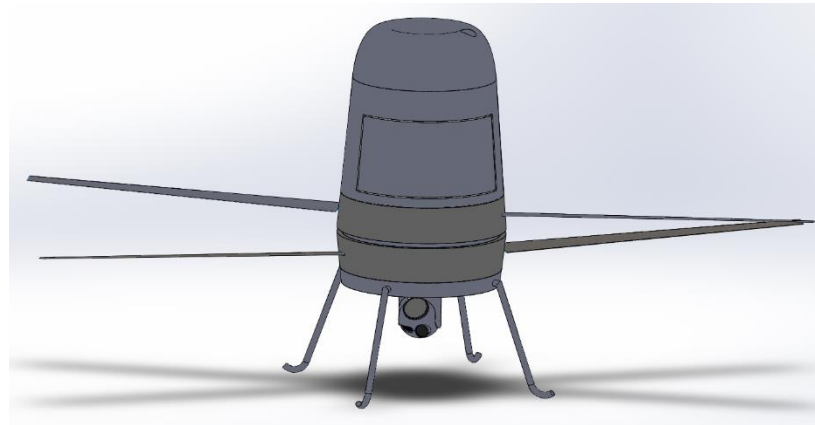

- Logistics / Agriculture : 2h endurance with 60 kg payload

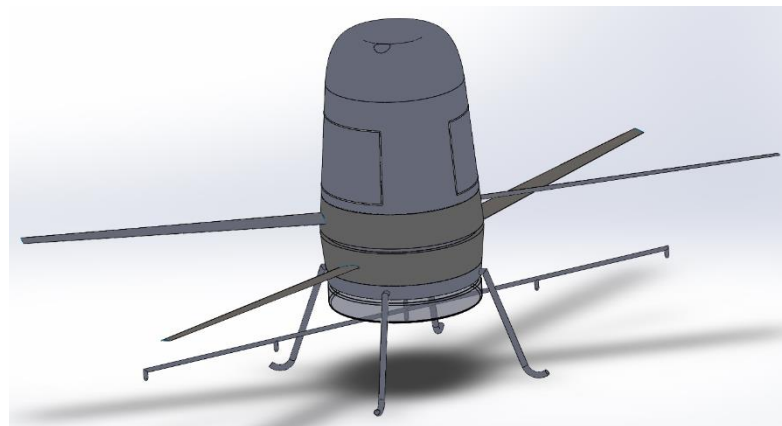

S-110 Drone Modular Architecture

Auxiliaries – Antennas - Autopilot

Motor – Compressor – Fuel tank

Chassis & Rotors,

Cyclic and collective Servos

Payload and landing gear supports,

yaw control units

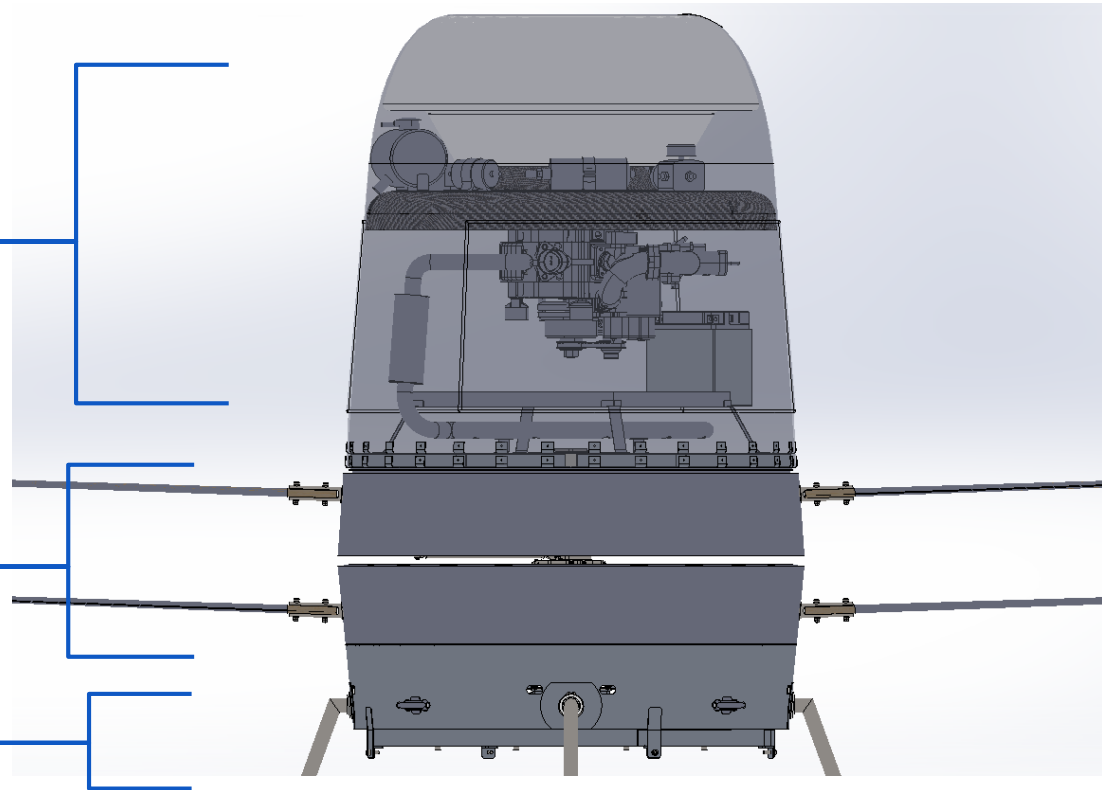

→ Quick and simple connections between the modules for easy maintenance

Competitors

Brand, model	MTOW (kg)	Payload (useful + fuel) (kg)	Endurance (h)	Note
Schiebel Camcopter (A)	200	50 + 40f	5,5	Empty 110 kg Wankel 40 kW
SAAB Skeldar (S)	235	40 + 60f	6	Empty 135 kg 2T 41 kW
Leonardo Hero (It)	205	35 + 50f	6	Empty 120kg
Yamaha RMax (J) Northrop R-Bat(US)	93	19	4	2T 15,4 kW
Higheye (NL)	21,5	2,2 + 4f	4	Empty 15,4 kg
Uavos UVH 290E (USA)	107	= 5 + 29f	5..6	Empty : 73 kg Wankel 17 kW Rotor 3,2 m
Indra Pelicano CybAero Apid (E)	160	55 = 30 + 25f	3	Empty : 105 kg
Pulse aerospace Radius 65 (USA)		12,5 + xf	5	
IT180-120 ECA (F)	16	5 + x f	2	Coaxial rotor

TDR technology presentation

Working principle

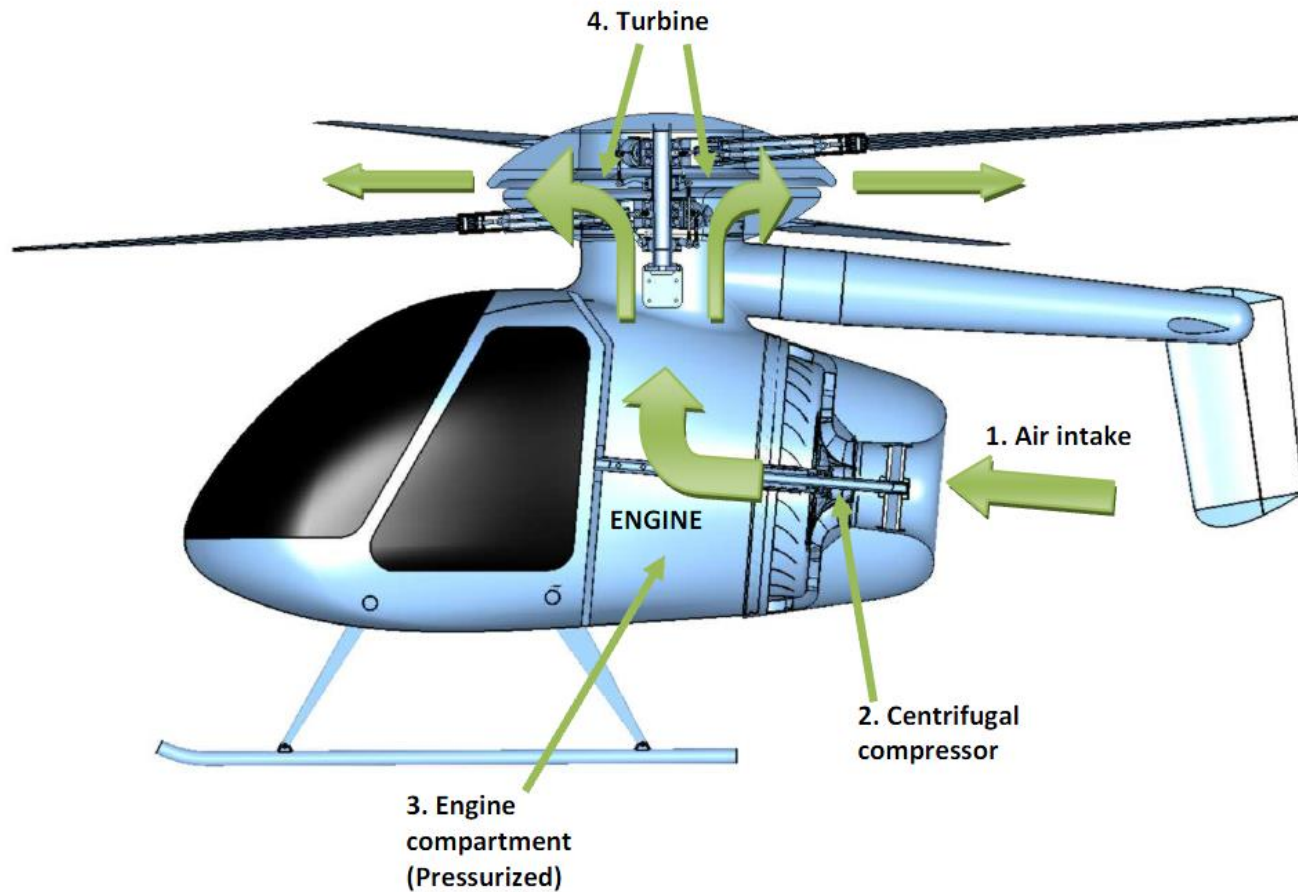

Compressor

Carbon Epoxy rotor



Turbine

Solid machined aluminium

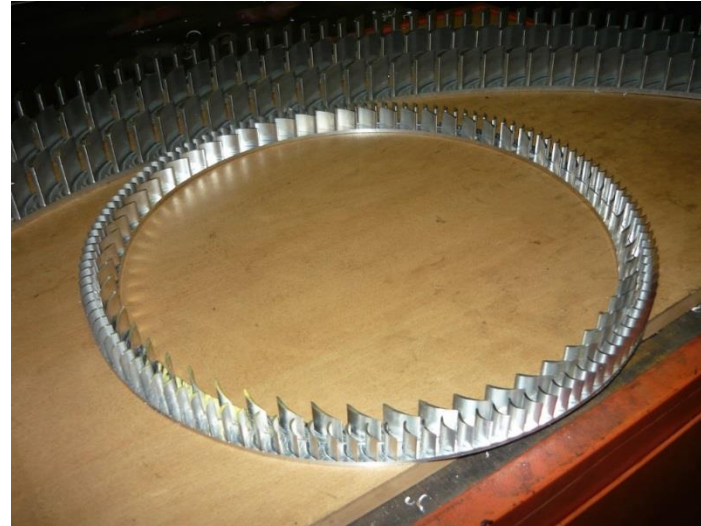

Blade

Composite material

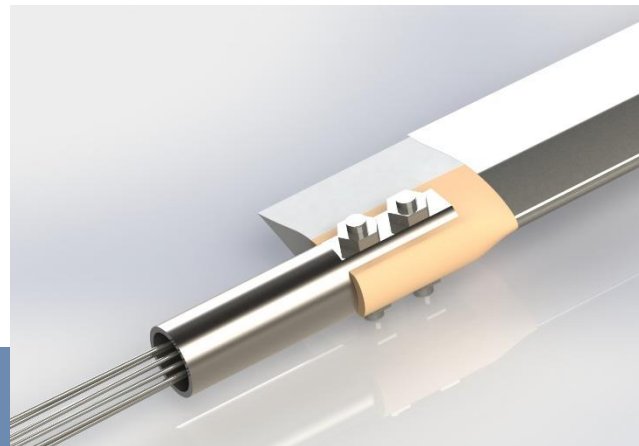

S75 DRONE DEMO FLIGHT



S-110 Drone vis à vis other UAV solutions

- **FIXED WING**

- S-110 Drone: Is more flexible to use, no need for take off or landing strip / catapult
- Has better all weather capacity, excellent resistance to gusts
- Can hover

- **ELECTRICAL MULTICOPTERS**

- S-110 Drone: Has better autonomy, 11 hours versus 20 minutes
- Has higher payload capacity, high payload to MTOW ratio
- Is less sensitive to wind and gusts, has a more efficient rotor

- **MECHANICAL DRIVE SMALL HELICOPTERS**

- S-110 Drone: Has a low purchase price
- Has high reliability (no mechanical parts other than the engine)
- Has low maintenance requirement, low mechanical vibrations

FEATURES & PERFORMANCES of the S-110 Drone

- Easy installation of the payload on a large (600 mm diameter) support
- Modular design: Good accessibility and easy to assemble / disassemble
- Smooth transmission, no mechanical transmission vibrations and shocks, important when operating cameras.
- Compact size
- Payload installation below and above the rotor
- Yaw stability due to the circular shape of the fuselage
- Low IR signature and fire danger due to low temperature exhaust gases
- Good reliability: No wear, no lubrication, no cooling
- Good hovering efficiency (contrarotating coaxial rotor)
- Low empty weight / MTOW ratio
- Low acquisition and operating cost

REDUCING THE COMPLEXITY OF COAXIAL ROTOR

Traditional mechanical transmission

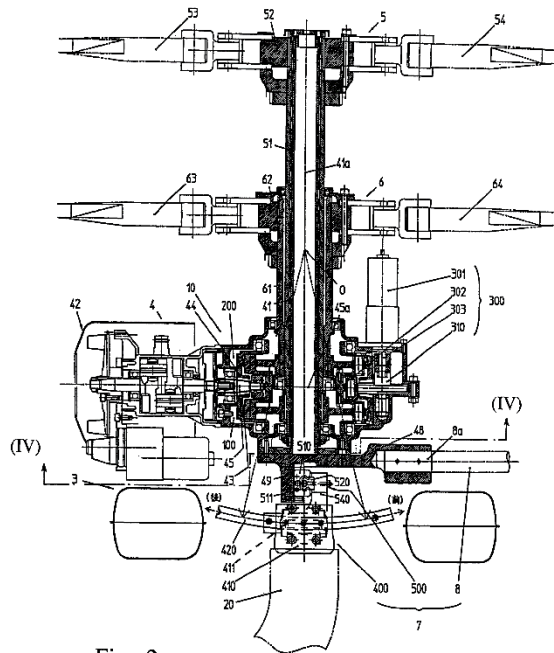
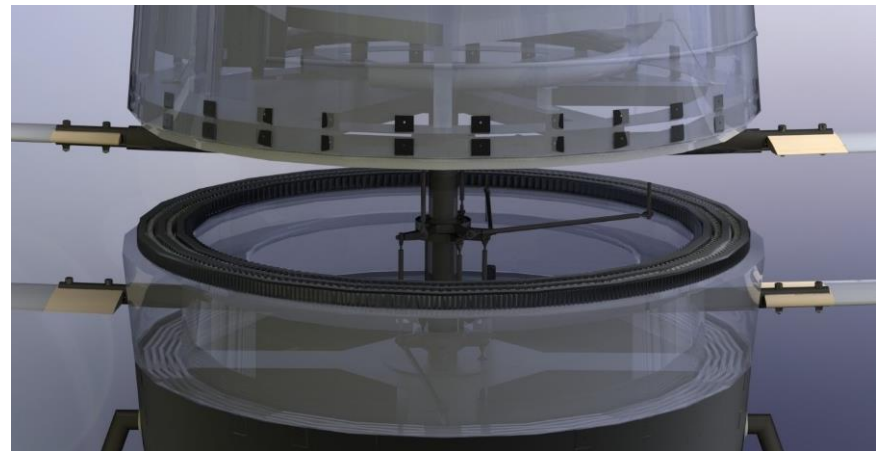
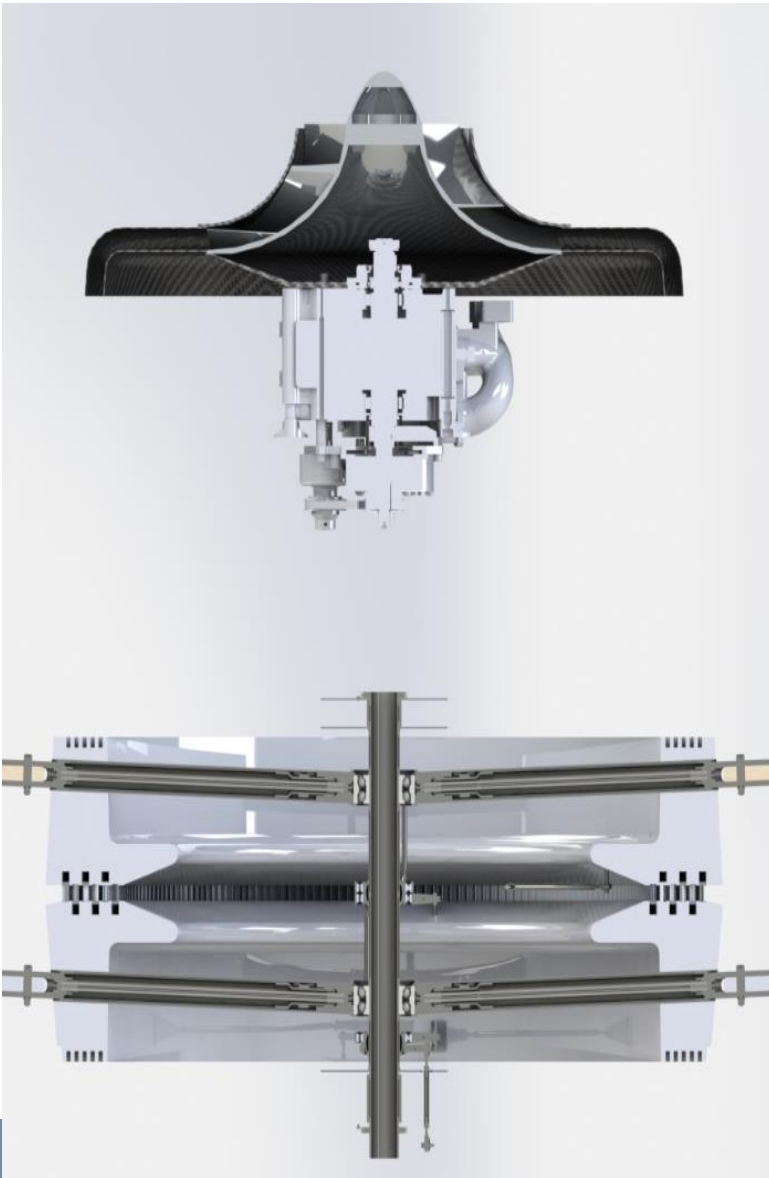

Fig. 2

REDT® system



Sustentation Aero Module of S-110 Drone



1 Stage centrifugal compressor
mass flow 0,75 kg/s

Motor 30 kW Wankel

Upper rotor, span 2,99 m

Turbines, 6 stages

Lower rotor, span 2,99 m



Contact: info@sagita.be

SAGITA SA Chemin de la Cloche 7 B-4130 Esneux tel +32(0)497528964

www.sagita.be